

**AUXILIARY FRAMING CHANNEL, 2" X 1" X 3/16"**

Modified:10/14/2009

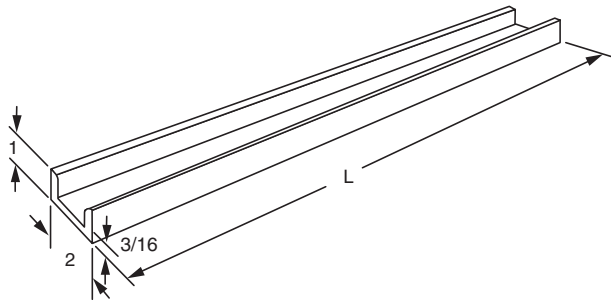

| Ordering Table | part number | length |
|----------------|-------------|--------|
|                | 00100201xx  | 2'     |
|                | 00100202xx  | 4'     |
|                | 00100203xx  | 6'     |
|                | 00100204xx  | 8'     |
|                | 00100205xx  | 10'    |
|                | 00100206xx  | 12'    |
|                | 00100207xx  | 14'    |
|                | 00100208xx  | 16'    |
|                | 00100209xx  | 18'    |
| 00100210xx     | 20'         |        |

**Notes:**

- XX = finish code; standard finish, XX = 30.
- Material: hot rolled steel.