

## Overture Networks HN6100



The HN6100 supports Ethernet over Copper customer premises equipment (CPE) via Overture Networks' HN400 Series, Ethernet over Time Division Multiplexing (TDM) and Ethernet over DS3 and NxT1/E1 via the new HN500 Series and TDM over Ethernet CPE via the new HN600 Series with PWE3-plus, Overture Networks' revolutionary, patented method of simultaneously transporting native Ethernet and native TDM over copper for Mobile Backhaul solutions. The same HN6100 multi-service chassis will also support Ethernet over Fiber interfaces.

The HN6100 delivers TDM, and Ethernet services in an economical, pay-as-you-grow package, which easily scales in capacity. The HN6100 supports Overture Networks' patented Pseudowire-Plus (PWE3-plus). PWE3-plus enables Carriers to dynamically assign bandwidth to TDM (DS1/E1) and Ethernet services which are natively supported over the PWE3-plus, delivering a carrier-class service. HN6100 can support up to 480 Mbps over a bonded link of 32 copper pairs. The HN6100 can transport Ethernet services with copper (Ethernet over Bonded Copper) and/or T1/E1 bonding (Ethernet over TDM) providing flexible Ethernet business service delivery over any rate or reach in a single platform.

The HN6100 enables Carriers to deploy an unlimited portfolio of services. For Ethernet, it supports a robust suite of hierarchical traffic shaping, policing, COS, QOS, and VLAN features. For DS1/E1, these services are natively supported (not emulated). This means that the cell towers and the legacy PBXs will receive a DS1/E1 with all of its native technical specifications that are needed including timing synchronization. For those instances when an emulated T1/E1 is desired, the HN6100 can deliver this as well.

The HN6100 addresses the synchronization issues that are prevalent with emulated T1/E1 services. The HN6100 delivers a synchronization solution that is fast, reliable, and accurate where every interface port can be synchronized to a reference clock (including the Ethernet ports), and these same interfaces can serve as a clock source. This enables an extremely flexible and resilient sync-in sync-out architecture. Included in the design are Stratum 3 and 4 holdover options, and a BITS input.

The HN6100 excels in delivering carrier-class resiliency, boasting 99.999% availability. It supports a sub-50 ms switch-over for TDM traffic, which ensures that there are no dropped calls. The HN6100 can be initially deployed in a low-cost, non-redundant configuration and can be easily field-upgraded so that there is no single-points-of-failure. In fact, the HN6100 extends its resiliency across the WAN/LAN and by using the PWE3-plus (EFM), DS3 and NxT1/E1 (EoTDM), and IEEE 802.3ad Ethernet Link Aggregation, traffic is not interrupted when a failure affects a line in any of the bonded groups. In all cases, a network fault will have a minimal impact on the remaining physical medium and the services they carry.

With the HN6100, a carrier can quickly deliver a new service. To simplify the identification of copper pairs, the HN6100 supports tone-generation and open/short technologies. To qualify the loop, the HN6100 includes Overture's TDR, an integrated Time Domain Reflectometer. With this technology, a carrier can measure the distance of the loop, analyze the quality of the loop, and detect the presence of the CPE (even when it is powered-off). Provisioning is easy and fast because the HN6100 will automatically configure the CPE in a plug-and play manner. It also automatically configures the modulation on the bonded-pair to obtain the highest data rate.



### Applications:

- Ethernet Business Services via Copper, Circuit, or Fiber
- Mobile Wireless Backhaul
- DSLAM Backhaul
- Transparent LAN Services
- Dedicated Internet Access
- Private Line Ethernet Services
- Layered VoIP Transport
- Multi-Tenant Ethernet Services

The HN6100 enables the proactive monitoring of service variables such as uptime, latency, and jitter. Within the network layer, the HN6100 supports multiple levels of resiliency for network protocols, paths, systems, and management. This includes network redundancy with 802.3ad, STP, and RSTP. Within the physical layer, the HN6100 provides a dynamic level of protection against service interruptions. This includes self-healing bonding engines, cross-card bonding, and no single point of failure. The HN6100 allows carriers to use familiar CFM tools to trouble shoot the service path, such as PING, TRACEROUTE, loop backs and performance monitoring capabilities.

With Overture Networks' HN6100, carriers can cost-effectively deploy native DS1/E1, high-speed Ethernet Services (via Ethernet over Bonded Copper and/or Ethernet over TDM), and PWE3 services to business sites and cell towers.

The HN6100 is NEBS level 3 certified, temperature-hardened, and has full front access to all of its cables and plug-in modules. Its 2 RU-high chassis can be deployed in a central office, a controlled environmental vault, an outside plant remote-terminal, a cell site, or at the customer's premise.

	T1/E1	PWE3/EFM	Dual Bearer	PWE3-plus
Line Reliability	No		No	Yes
System Reliability			No	Yes
Flexibility	No		No	Yes
Capacity	No			Yes
Latency and Jitter		No		Yes
Quality Clock		No		Yes
Bit Error Performance		No		Yes
Simplicity			No	Yes
Flexibility			No	Yes
Efficiency		No		Yes
Protection	No	No	No	Yes
Evolution	No			Yes

Figure 1: Overture Networks' PWE3-plus technology delivers unequaled value.

## What is Overture Networks' Pseudowire-Plus?

PWE3-plus delivers an un-altered TDM and Ethernet flow (aka Native TDM and Native Ethernet) that delivers real DS1/E1 – it is not emulated. An emulated service, like Pseudo wires, alters many of the characteristics of the native service. In the process, it is likely that there will be a loss in performance, timing, and synchronization. Overture believes that an emulated service is never as good as the original, and we developed our patented PWE3-plus solution to address this key requirement.

## Why is PWE3-plus better than T1/E1, PWE3, and Dual Bearer?

(Please see Figure 1)

### PWE3-plus delivers accurate and reliable timing.

- PWE3-plus has no adaptive timing and wander
- PWE3-plus delivers fast and immediate synchronization
- A PWE3-plus bonded group provides network resiliency
- PWE3-plus meets every synchronization specification for DS1/E1s

### PWE3-plus delivers better native TDM

- PWE3-plus's native TDM does not wait behind large packets on a congested link like PWE3
- PWE3-plus's native TDM does not wait to accumulate into a large (192B or 256B) PWE3 packet
- PWE3-plus does not sacrifice efficiency to improve latency
- A PWE3-plus bonded group provides network resiliency
- PWE3-plus scales in capacity, a T1 is strictly 1.54 Mbps
- PWE3-plus delivers a DS1/E1 that meets all of the required specifications. It is a native DS1/E1.

## Key Features:

- TDM and Ethernet Services
- Native DS1/E1 and Ethernet
- Services (EFM, and EoTDM, and TDM over Ethernet)
- Spectrally compliant for all markets
- 40 Gbps Switching Capacity
- Up to 80 Native DS1/E1 or 80 PWE3-plus Ports
- Up to 15 Mbps per copper pair, and 32 Pairs per Bonded Copper Group (420 Mbps)
- Ethernet over NxT1/E1 (bond up to 16 T1s or E1s)
- Ethernet over DS3 - bond up to 420 T1s or 330 E1s, X.86 Supporting up to 15 DS3s per 2RU
- 200 Bonded Groups
- Advanced QoS
- Multiple Services per EVC
- E-LINE, E-LAN, E-TREE
- Extensive SLA Management
- Robust Security
- TDR for qualification and maintenance of copper facilities
- IEEE 802.3ah Certified
- MEF 9, 14, 21 Certified
- NEBS level 3 Certified
- Carrier-Class OAM
- Stratum 3 & 4 Redundant Failover (50ms failover)
- +24vDC / -48vDC
- 99.999% Availability
- Environmentally Hardened

## Overture Networks Solutions for Business Access and Mobile Backhaul

### Why Overture Networks?

- Simpler faster deployments and maintenance
- Reduced cost and complexity
- Better performance, latency, throughput

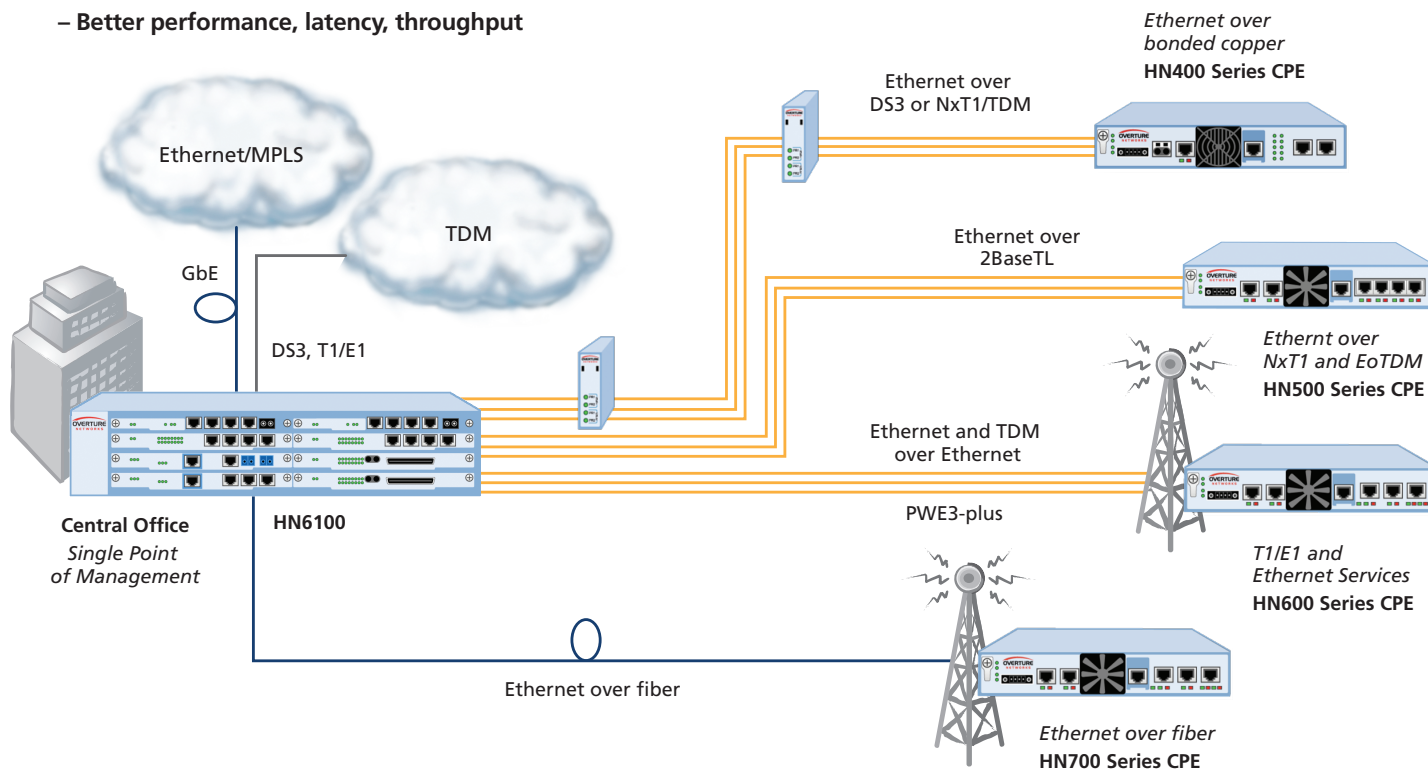

Figure 2: HN6100 delivers Ethernet over Bonded Copper, Ethernet over TDM and TDM over Ethernet Solutions.

### HN6100 delivers Carrier-Class services and an efficient migration to Ethernet

Service providers and Mobile Operators desire an Ethernet Access Network because it promises the ability to deliver multiple services over a low-cost infrastructure. The HN6100 delivers on this promise. It addresses the Operator's immediate need to support legacy DS1/E1 services, while enabling an efficient migration to the high-bandwidth requirements for Ethernet Services.

With the HN6100, DS1/E1 interfaces are software-defined to be used as native-TDM and/or PWE3 ports. These same DS1/E1s can be software-defined to do Ethernet over Bonded Copper or Ethernet over TDM. With Overture's HN6100, Ethernet Services easily scale up to 480Mb per 32 bonded pairs.

With the HN6100, every interface can be synchronized to a reference clock, whether it is a DS1/E1 interface, an optical Ethernet interface, or a PWE3-plus interface. Likewise, any interface can serve as a clock source. This enables an extremely flexible sync-in sync-out architecture.

The HN6100 is an ideal architecture to migrate the TDM centric network to end-to-end Business Ethernet Services.

#### HN6100 Backhaul and Midband Ethernet Applications

- Bookended or aggregation
- PWE3-plus, TDM, and/or Ethernet Services (over Bonded Copper or EoTDM)
- Separate TDM/Ethernet networks @ CO
- One or more operators at the cell tower
- DSLAM backhaul w 32-pair bonding and GigE
- Interoperability with HN400s, HN500s, HN600s
- Up to 32-pair bonded copper for 480 Mbps aggregate bandwidth
- EoTDM via NxT1/E1 and DS3 (X.86) supporting 420 T1s and 15 DS3s respectively
- PWE3-plus for T1/E1 services (legacy PBX)

## Product Features

### Interfaces

- 16 Port/Pair Copper supporting IEEE 802.3ah, 2BASE-TL, ITU-T G.991.2.bis (Annex A, B, F, & G). ANSI T1.417 Spectral compliance and UK ANFP Spectral compliance. 4 RJ-45 Ports. Sealing current applied to all copper pairs.
- 16 Port DS1/E1 that is software definable to support Native T1/E1, and Ethernet over bonded T1/E1 (EoTDM) via Amplimite 68 Pin connector
- 3 Port DS3 Interface that is software definable per port to support channelized operation to DS1/E1 or Clear Channel configuration to support X.86 encapsulation.
- Two versions of the 14 Gbps switch control processor
- 2 Port 1000BASE-X (SFP)
- 2 Port 100/1000 Base-TX
- DS1/E1 BITS/SETS Input on Auxiliary Card via RJ-45 connector
- 3 Alarms Inputs and 2 Outputs on Auxiliary Card via RJ-45 connector
- Metallic Loop Test IN and Test OUT interfaces via RJ-45 connector
- Craft Interface 10/100BASE-TX via RJ-45 connector

### Ethernet & Routing Features:

- DHCP server, NAT firewall, ACLs, Static Routes, RIPv2
- GMP Snooping
- MEF E-LINE, E-LAN, and E-TREE
- 802.1d Bridging
- 802.1q VLANs, VLAN stacking (aka Q-in -Q), S-VLAN
- 802.1p Prioritization
- 802.3x Flow Control and pause frames
- MAC Filtering
- All Ethernet Ports perform auto-negotiation, Full or half duplex
- VLAN Tag ID writing, stacking, stripping, and re-writing and VLAN Bundling and VLAN Pruning
- RFC 791 IP, RFC 792 ICMP, RFC 793 TCP, RFC 768 UDP, RFC 826 ARP, RFC 1122 Host Requirements
- Auto/Manual MDI/MDIX
- Local Switching between Ethernet Ports
- 2000 Byte MTU

### Traffic Management:

- 8 COS Classifications Mapped to 4 Queues
- Queue management using Customizable Weighted Fair Queuing,
- Strict Priority, and Combination
- COS based upon 802. 1p, VLAN ID (802. 1q), DSCP, and fixed per port
- Traffic Policing with dual leaky bucket algorithm
- Traffic Rate Shaping
- Broadcast, Multicast, and Unknown Storm Control

### Mechanical:

- 8 Slots:
- 2 slots for Auxiliary card, 1+0 and 1+1 configurable
- 2 slots for Switch Control Processors, 1+0 and 1+1 configurable (1+1 uses a service module slot)
- 5 slots for service modules
- Compact 2 RU size, full front access
- Dimensions: Width 17.45" (444mm); Height: 3.47" (88mm); Depth: 9.88" (251mm)
- Weight: 30 lbs (13.6 kg) fully populated
- Rack Mounting in 19" and 23" EIA/ANSI and WECO racks; 600mm wide ETSI racks
- Air Exhaust: rear or side exhaust, factory option
- Cooling: field replaceable fan unit with field-serviceable fan filter

### Management, Security, and Diagnostics:

- Craft Interface RS-232 via RJ-45 connector
- Imbedded Web GUI (Web Manager), Command Line Interface
- Telnet (client and server)
- FTP and TFTP
- RFC 1155 TCP/IP management
- RMON
- IEEE 802.3ah OAM
- SNTPv3 - Time Synchronization
- DHCP
- Error logging and SNMP Trap alarms based on GR-474-CORE and GR-883-CORE
- SSHv2, HTTP/HTTPS, SSL
- TACACS+ and RADIUS
- Management IP Access Control List
- Audit Log, Event Log, Boot Log, and Syslog

- Link Trace, Ping, L2 Ping, Trace Route
- Test TCP, Link Loss Forwarding
- Auto Discovery
- IEEE 802.1ag CFM
- ITUY.1731ETH-OAM
- CLEI Coded
- Traffic Generator/Monitor

### Electrical:

- Power: 150 Watts fully populated at -48 VDC with Redundant Feeds
- Optional AC/DC 120/240 power supply
- Input Voltage: -48V and +24V DC

### Certifications and Compliance:

- NEBS Level 3 (GR-63-CORE and GR-1089-CORE)
- GR-3108 Class 2
- IEEE 802.3ah-certified, 2BASE-TL, ITU-T G.991.2.bis (Annex A, B, F, & G). ANSI T1.417 Spectral compliance and UK ANFP Spectral compliance
- MEF Certifications: MEF 9, MEF 14
- FCC Part 15 Class A
- EN 55022 Class A
- ETSI EN 300 386, 300 753, 101 524
- ETSI 300 019, T1.2, T2.2, T3.1E
- Listed to safety 60950-1 / 60950-21, with CB scheme with all country deviations
- ITU: K20/K21
- C-Tick
- CE Mark
- RoHS: Compliance with Directive 2002/95/EC
- WEEE 2002/96/EC

### Environmental:

- Environmentally hardened with extended temperature range, -40°C (-40°F) to +65°C (+149°F)
- Error logging and SNMP Trap alarms based on GR-474-CORE and GR-883-CORE
- Storage and Transportation Temperature: -40C (-40F) to +70C (+158F)
- Operating Humidity: 5% to 85%, per GR-63
- Storage and Transportation Humidity: 5% to 95% non-condensing

Overture Networks, Inc.  
Research Triangle Park, NC  
tel: 919.387.4100  
www.overturenetworks.com

Overture Networks, Ltd.  
Warwick, UK  
+44 1926 840 045

RoHS  
compliant

  
**OVERTURE**  
NETWORKS