

Model 520-50

T1 Network Interface

Unit with Performance

Monitoring

General Description and Installation Practice

T1 Network Interface Unit with Performance Monitoring Model 520-50

Contents	Page
1. General	2
2. Applications	3
3. Functional Operation	3
4. Provisioning	5
5. Loopback	6
6. Power	7
7. Front-Panel Features	7
8. Installation	8
9. Testing	9
10. Set-Up and Operation	9
11. Inspection and Warranty	13
12. Specifications	13
13. Ordering Information	13

1. General

1.01 The HyperEdge T1 Network Interface Unit with Performance Monitoring, Model 520-50, terminates DS1 High Capacity Digital Services at the customer premises. The 520-50 is located between the Network and Customer Premises Equipment (CPE) on the network side of the demarcation point. Performance Monitoring allows the network side to be proactive in identifying potential problems and sectionalizing faulty conditions. The 520-50 also provides a loopback feature. Loopback enhances maintenance operations by allowing the Network Provider to remotely isolate and sectionalize problems thus, resulting in improved customer service.

1.02 Whenever this document is revised, the reason for revision will be stated in this paragraph.

1.03 Features:

- Slim-type mechanics (front panel is half the width of a standard 400-type mechanics unit)
- Local, non-intrusive access to PM parameters via a front-panel RS-232 craft interface port
- Performance Monitoring (PM) features
 - Data Retrieval
 - PM parameters for
 - Errored Seconds (ES)
 - Severely Errored Seconds (SES)
 - Unavailable Seconds (UAS)
 - Bipolar Violations (BPs)
 - Far End (FE)
 - CRC (Cyclic Redundancy Cycle)
 - LOS (Loss Of Signal)
 - AIS (Alarm Indication Signal)
 - PM Storage in 15 Minute, 1 Hour, 24 Hours and 7-day increments
 - PM Event Log with time stamped entries

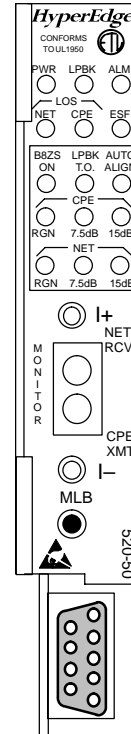

- Compatible with AMI and B8ZS line formats
- Inband, ESF Data Link and manual loopback activation and deactivation
- Manual Loopback option
- Single Loopback operation towards Network; Dual loopback mode toward Network and CPE
- Local Provisioning of CPE LOS Indication
- Front-panel Bantam-type Monitor jacks
- Pin-type test jacks for measuring span current
- Front Panel LEDs for:
 - Power (PWR),
 - Network Loopback (NTWK LPBK),
 - NET LOS (Network Loss Of Signal),
 - CPE LOS (CPE Loss Of Signal),
 - ESF (Extended Superframe Format), and
 - ALM (ALARM)
- Front-panel Provisioning functions for:
 - B8ZS,
 - LPBK T.O. Disable (Loopback Timeout),
 - Auto-align,
 - Net/CPE LBO of 7.5dB/15dB
 - Net/CPE Regen

- Powered from 60mA span current or locally from a –48Vdc external source
- Complies with UL1459 Issue 2 of the National Electric Code
- Complies with Bellcore GR–1089 Issue 1 for short circuit, lightning surge and power cross protection
- Temperature Hardened (–40°C to +65°C)
- Maintains performance statistics for each direction of transmission

2. Applications

2.01 The 520-50 is installed at the customer premises location on the network side of the point of demarcation between the Network and Customer Premises Equipment (CPE). The unit terminates DS1 (1.544Mb/s) HCDS derived over metallic cables or fiber multiplexed facilities. The 520-50 provides a maintenance loopback feature toward the Network. The 520-50 can be powered either from the span or from an external –48Vdc power supply. In addition to typical NIU functions, such as loopback, the NIU collects performance data from both directions of the facility and reports it to the remote test center. Performance information can be locally accessed via the front-panel RS-232 (DB9) craft interface port.

2.02 When installed into a new or existing HCDS circuit, the 520-50 must be included in the span design.

DS1 Transmission Design

2.03 The T1 transmission signal loss from the last line repeater to the network interface should not exceed 16.5dB. The unit has a maximum insertion loss of 1.0dB at 772kHz restricting the loss between the last line repeater and the 520-50 to less than or equal to 15.5dB.

2.04 The signal received from the Customer equipment should be limited so that the range of pulse amplitudes received at the last LEC repeater is controlled to ± 4 dB. This is accomplished by the customer adjusting the Customer Service Unit (CSU) for the correct Output Pulse Option setting. The Output Pulse setting is based on the cable loss between Customer equipment and the last Network repeater plus the 1dB insertion loss, as specified by the Network at the time of installation.

Power

2.05 When the unit is powered from the span, it has a voltage drop of 28Vdc (466 Ohms at 60mA). The 466 Ohms must be added to the simplex resistance of the span when calculating the required span voltage.

3. Functional Operation

3.01 See Figure 1, the 520-50 Block Diagram, as needed, while reading the following description of operation.

Side 1 and Side 2 Transmission Paths

3.02 The 520-50 is transformer coupled on all transmission ports. The network transformers are center tapped to provide a loop termination for span current. The network ports are also equipped with secondary lightning and surge protection circuits. Depending on the operational mode, Side 1 (RCV from NET) and Side 2 (XMT to NET) transmission paths can be active or passive.

Framing Formats and Line Codes

3.03 The 520-50 automatically interfaces signals using either SF or ESF framed or unframed code formats. The unit will also accommodate line codes using either AMI or B8ZS formats. The unit responds to specific signal codes to activate various features. Detection of these codes will function with a bit-error rate of 10^{-3} , or less, on the facility.

Loss of Signal Detection

3.04 The 520-50 monitors both transmission paths for loss of signal. Whenever a loss of signal is detected from either side, the appropriate front-panel NET LOS or CPE LOS LED will light. Also, when a loss of signal is detected from the Network, the unit will send an Alarm Indication Signal (AIS) toward the customer. Whenever a loss of signal is detected from the CPE, the unit will respond to the loss in accordance with how the CPE LOS feature is set (see paragraph 4.02 for details).

CPE Regeneration (Transmit Path)

3.05 The transmit path (Side 2) has the ability to perform signal regeneration. Signal regeneration recovers the signal from the CPE and regenerates it to a 0dB level toward the network or DSX. See paragraph 4.10 for details.

CPE LBO (Transmit Path)

3.06 The Side 2 (XMT To NET) path is also equipped with an LBO circuit to attenuate the signal being sent to the Network. The LBO circuit can be adjusted for 0, 7.5 or 15dB of loss. See paragraph 4.11 through 4.12 for details on how to set the CPE LBO option.

Network-Side Regeneration (Receive Path)

3.07 The receive path (Side 1) has the ability to perform signal regeneration. Signal regeneration recovers the DS1 signal from the Network side and regenerates it to a 0dB level toward the CPE. See paragraph 4.13 for details.

Network-side LBO (Receive Path)

3.08 The Side 1 (RCV from NET) transmission path is equipped with an LBO circuit to attenuate the signal received from the Network. The LBO circuit can be adjusted for either 0, 7.5 or 15dB of loss. See paragraph 4.14 through 4.15 for details on how to set the NET LBO option.

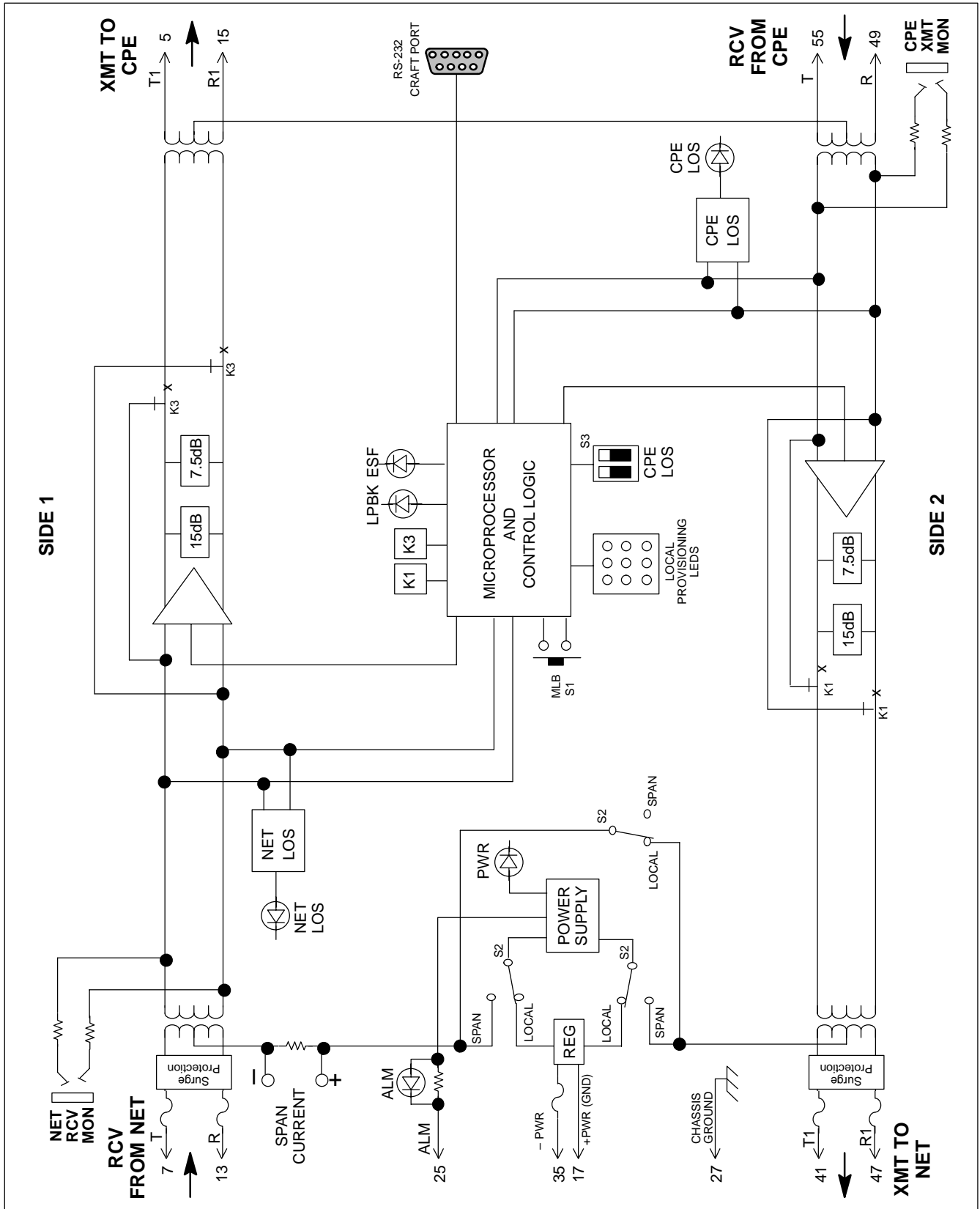

Figure 1. 520-50 Block Diagram

4. Provisioning

Local Provisioning Features

4.01 The 520-50 provides the ability to be locally provisioned via the front-panel MLB button or using the S3 switch option. See Figure 2 for the Option and Front-Panel diagram. The following features can be locally provisioned:

CPE LOS: AIS, LPBK, CDI or Terminate,
 B8ZS: ON/OFF
 LPBK T.O.: ENABLE/DISABLE
 AUTO-ALIGN: ON/OFF
 CPE REGEN: ON/OFF
 CPE LBO: 0dB, 7.5dB or 15dB
 NET REGEN: ON/OFF
 NET LBO: 0dB, 7.5dB or 15dB

CPE LOS Provisioning

4.02 The 520-50 can be configured to send an Alarm Indication Signal (AIS), enter Loopback (LPBK), send a Customer Disconnect Indication (CDI), or to terminate the CPE upon detecting a customer loss of signal. The installer must first set option switch S3 (see Figure 2) on the main printed circuit board to configure the unit for the appropriate response upon a loss of signal from the customer.

Note: When set for CDI, the unit will continuously send the inband code 0001 0111 (17 HEX) toward the Network whenever a loss of signal is detected from the CPE. If ESF format is received from the Network, eight 1s followed by eight 0s (interrupted each second for 100ms with LAPD idle code – 001111110), will be sent in the Data Link. When the customer signal is restored, CDI will stop and the circuit will return to normal operation.

4.03 Once S3 is set, simply press and hold the front-panel MLB button. After about three seconds, the Provisioning LEDs will flash once. The unit will then enter the Provisioning Mode and begin to flash the B8ZS option LED. **Note:** During Provisioning, each Provisioning LED will flash in sequence for approximately 4-seconds in which the installer has to make a decision to enable or disable the option.

B8ZS Provisioning

4.04 To select the B8ZS function, press the MLB button during the 4-second time frame. The B8ZS LED will light steady then scroll to the next option – LPBK T.O. If the MLB button is not pressed, the unit will automatically set the B8ZS option to OFF (i.e., AMI – ON) and scroll to the next Provisioning LED – LPBK T.O.

4.05 When the LPBK T.O. option LED begins flashing, the installer has four seconds to make the decision to enable or disable the timeout option.

Loopback Timeout Provisioning

4.06 If 120-minute Loopback Timeout feature is desired, press the MLB button once. The LPBK T.O. LED will light steady then scroll to the next option – Auto Align. If the MLB button is not pressed, the

unit will automatically set the LPBK T.O. option to OFF then scroll to the next option – AUTO ALIGN.

AUTO ALIGN Provisioning

4.07 The unit can be set to enter the Auto Align mode either in the CPE or Network direction. The operation of this mode is as follows:

If the network signal drops below a level of –15, the unit will automatically enable the RCV path REGEN circuit and insert a 7.5dB pad toward the CPE. Similarly, if the customer's signal drops below the level of –15dB, the unit will automatically enable the XMT path REGEN circuit and insert a 7.5dB pad toward the Network.

4.08 While the AUTO ALIGN LED is flashing and if Auto Align is desired, press the MLB button once within the 4-second time frame. The AUTO ALIGN LED will light steady. **Note:** If the Auto-Align feature is selected, further provisioning is not required.

4.09 If Auto-Align is not selected, the Auto Align feature is set to OFF and the unit will scroll to the next option – CPE REGEN.

CPE REGEN Provisioning

4.10 While the CPE REGEN LED is flashing and if a regenerated signal to the network is desired, press the MLB button within the 4-second time frame. The CPE REGEN LED will light steady then scrolls to the next option – CPE 7.5dB.

CPE 7.5dB LBO Provisioning

4.11 If 7.5dB of LBO is required in the transmit path, press the MLB button during the 4-second time frame. The CPE 7.5dB LED will light steady and the unit scrolls to the next option – CPE 15dB.

If the MLB button is not pressed during the 4-second time frame, the unit automatically sets the CPE 7.5dB option to OFF and scrolls to the next option.

CPE 15dB LBO Provisioning

4.12 If 15dB of LBO is required in the transmit path, press the MLB button during the 4-second time frame. The CPE 15dB LED will light steady and scrolls to the next option – NET REGEN.

Note

If the MLB button is not pressed during the 4-second time frame, the 7.5dB and 15dB LBO LEDs stop flashing and the unit automatically sets the CPE LBO option to 0dB.

NET REGEN Provisioning

4.13 While the NET REGEN LED is flashing and if a regenerated signal to the customer is desired, press the MLB button within the 4-second time frame. The NET REGEN LED will light steady then scroll to the next option – NET 7.5dB.

NET 7.5dB LBO Provisioning

4.14 If 7.5dB of LBO is required in the receive path, press the MLB button during the 4-second time frame. The NET 7.5dB LED will light steady then scroll to the next option – NET 15dB.

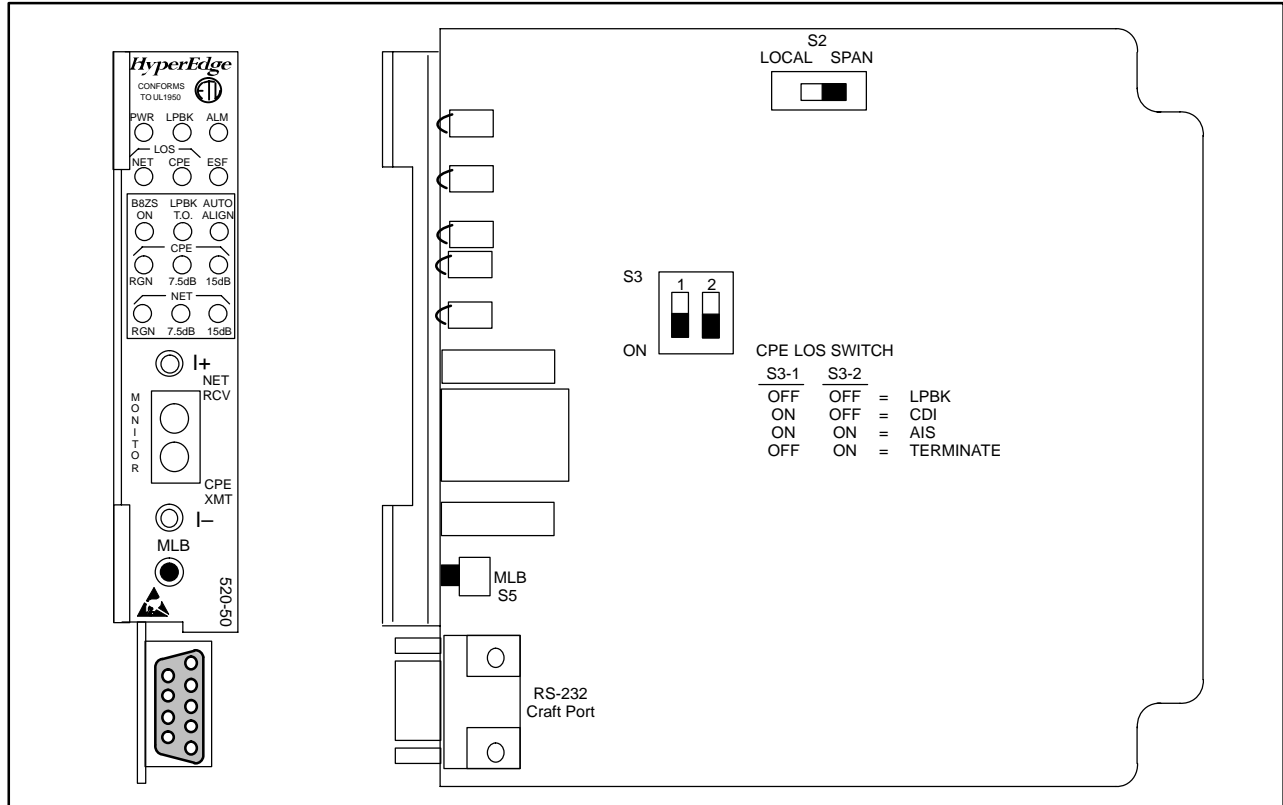

Figure 2. 520-50 Option Location and Front Panel Diagram

If the MLB button is not pressed during the 4-second time frame, the unit automatically sets the NET 7.5dB option to OFF then scrolls to the next option.

RCV 15dB LBO Provisioning

4.15 If 15dB of LBO is required in the receive path, press the MLB button during the 4-second time frame. The NET 15dB LED will light steady and the unit returns to normal operation .

Note

If the MLB button is not pressed during the 4-second time frame, the 7.5dB and 15dB LBO LEDs stop flashing and the unit automatically sets the NET LBO option to 0dB and returns to normal operation.

Factory Default Feature Setting

FUNCTION	DEFAULT
B8ZS	OFF
Loopback T.O.	ON (120 Minutes)
Auto Align	ON
CPE REGEN	OFF
CPE 7.5dB LBO	OFF
CPE 15dB LBO	OFF
NET REGEN	OFF
NET 7.5dB LBO	OFF
NET 15dB LBO	OFF

5. Loopback

5.01 An important function of the 520-50 is the Network Loopback. Network Loopback loops the signal from Side 1 back to the Network on Side 2. The unit provides fixed regeneration in the loopback path. Upon a Network loopback, the unit will apply the correct termination toward the CPE transmit and receive path and prevent excessive crosstalk from occurring in adjacent cable pairs.

5.02 The 520-50 provides two loopback modes; Network (single) and/or Network and CPE (dual) loopback. When Network Loopback is activated, the signal received from the Network on Side 1 (RCV path) is looped back toward the Network on Side 2 (XMT path). Signal regeneration is provided while in loopback. When CPE-side (dual) Loopback is activated, the signal received from the CPE (Side 2 or XMT IN port) is looped back toward the CPE on Side 1 (RCV OUT port). **Note:** CPE-side (dual) Loopback can only be accomplished by placing the unit into a Network-side loopback first. Please also note that Loopback can be activated/deactivated manually via the front-panel MLB push button.

5.03 Loopback can be activated or deactivated in the presence (or absence) of signal on the CPE side. Loopback can also be activated or deactivated with the presence (or absence) of a CPE termination on Side 1.

Manual Loopback

5.04 Manual activation of loopback is achieved by pressing the front-panel Manual Loopback switch (MLB) for one second. When the MLB switch is pressed and released, the LPBK LED lights steady and a Network-side loopback is established. Loopback remains in effect until the MLB switch is pressed a second time (i.e., less than 3 seconds) or a loopback deactivate code is received. When the unit is in a Network-side Loopback, CPE Loopback (dual) can be manually activated by pressing the front-panel MLB switch for three seconds. After three seconds, the LPBK LED will begin flashing. CPE Loopback will remain in effect until the MLB switch is pressed a second time or the loopback deactivate code is received.

Inband Loopback Activate/Deactivate

5.05 The repetitive pattern 11000 applied to Side 1 (RCV path) will place the unit into loopback. After five seconds of the code being applied, the unit will enter loopback and, if enabled, activate the 120 minute timeout circuit. Testing of the circuit can be done at this point. **Note:** The inband code can be sent either unframed, SF framed or ESF format. The repetitive pattern 11100 applied to Side 1 (RCV path) of the unit for more than five seconds returns the unit to normal operation.

ESF Data Link Loopback

5.06 While operating in ESF, the network can use a 4kb/s Data Link in the DS1 signal to transmit loop-up/loop-down control codes to the unit. The ESF loop-up code is 0001 0010 1111 1111 (12FF HEX). The ESF loop-down code is 0010 0100 1111 1111 (24FF HEX). The unit will respond to ESF DL commands within 16ms of receiving code.

Remote Loopdown During CPE LOS (Code)

5.07 When the CPE LOS option is configured for LPBK, AIS or CDI, an override of the action during a CPE LOS can be accomplished by sending the loop-down code 11100. However, the unit must first be looped up if the unit is not optioned for CPE LOS LPBK. In the override mode, the unit will remain in the override mode for three minutes. If the override mode times out and the customer signal is still not present, the unit will return to the previously optioned CPE LOS action (LPBK, CDI or AIS). If the override mode times out and the customer signal is present, the unit will return to normal operation.

Manual Loopdown During CPE LOS (MLB)

5.08 When the CPE LOS option is configured for LPBK, AIS or CDI, an override of the action during a CPE LOS can be accomplished by momentarily pressing the front-panel MLB switch. However, the unit must first be looped up if the unit is not optioned for CPE LOS LPBK. In the override mode, the unit will remain in that mode for three minutes. If the override mode times out and the customer signal is still not present, the unit will return to the previously optioned CPE LOS action (LPBK, CDI or AIS). If the

override mode times out and the customer signal is present, the unit will return to normal operation.

6. Power

6.01 The unit can be powered from either a local external –48Vdc power source or from span current via the facility. Option switch S2 (SPAN/LOCAL) is used to configure the unit for the proper power source operation.

Local Power

6.02 When powered from an external source, the unit will operate from a –22.5 to –56Vdc (–48Vdc typical) power source. Set switch S2 to the LOCAL position. The unit will now provide a simplex loop toward the span. The unit's external power lead is fused and provides an alarm output (pin 25) for external reporting of a local power alarm. The front-panel ALM (Alarm) LED will light steady if the power fuse opens.

Span Current Pin Jacks

6.03 The unit can be powered via the Span and is equipped with two pin-type jacks, designated I– and I+, on the front panel and provide easy access for measuring span current. When Span Powered, set switch S2 to the SPAN position. When Span Powered, the unit will add an additional 466 Ohms of simplex resistance at 60mA.

7. Front-Panel Features

7.01 The unit is equipped with two DC isolated bantam jacks located on the front panel labeled as CPE XMT MON and NET RCV MON. The CPE XMT MON jack allows for monitoring signals in the CPE-to-Network (SIDE 2) path. The NET RCV MON jack allows for monitoring the signal from the Network toward the CPE (SIDE 1). **Note:** Both the CPE and NET MON jacks are equipped with the proper termination resistance.

7.02 The 520-50 has 15 front-panel LEDs which provide status information as follows:

- PWR** LED is ON steady when power is applied
- LPBK** LED is ON steady when unit is in normal network loopback. LED flashes when the unit is in the dual loopback mode or if the unit is in loopback due to a CPE LOS
- ALM** LED is ON steady when fuse is open
- NET LOS** LED is ON steady when loss of signal from the network is detected
- CPE LOS** LED is ON steady when loss of signal from the customer is detected
- ESF** LED is ON steady when ESF signals are detected from the network

Provisioning LEDs

Each LED will flash, one at a time and in 4-second intervals when local provisioning begins.

B8ZS LED flashes when local provisioning begins. Press MLB switch once to set unit for B8ZS format. Do not press MLB switch to set unit for AMI format. Unit will sequence to next Provisioning LED option.

LPBK T.O. LED flashes when local provisioning begins. Press MLB switch to enable 120-minute loopback timeout. Do not press MLB switch and 120-minute loopback timeout remains disabled. Unit will sequence over to the next Provisioning LED option.

AUTO ALIGN LED flashes when local provisioning begins. Press MLB switch once to activate Auto Align mode. LED lights steady, enables Regen and inserts 7.5dB of attenuation if level drops below -15dB in either direction **Note:** If pressed, no further provisioning is required. Do not press MLB switch, auto align is not activated. Unit scrolls to the next option.

CPE RGN LED flashes when local provisioning begins. Press MLB switch to enable XMT Regen. This LED is ON steady when provisioned for REGEN ON toward the network. Do not press MLB switch and CPE Regen remains disabled. Unit scrolls to the next option.

CPE LBO 7.5dB LED flashes when local provisioning begins. Press MLB switch once to enable 7.5dB loss in transmit path. Do not press MLB switch, 7.5dB remains disabled. Unit scrolls to the next option.

CPE LBO 15dB LED flashes when local provisioning begins. Press MLB switch once to enable 15dB loss in transmit path. Do not press MLB switch, 15dB remains disabled. Unit scrolls to the next option.

Note

If MLB switch is not pressed for either the 7.5 or 15dB CPE LBO option, unit automatically sets CPE LBO option to 0dB.

NET RGN LED flashes when local provisioning begins. Press MLB switch to enable RCV Regen. This LED is ON steady when provisioned for REGEN ON toward the customer. Do not press MLB switch and NET Regen remains disabled. Unit scrolls to the next option.

NET LBO 7.5dB LED flashes when local provisioning begins. Press MLB switch once to enable 7.5dB loss in receive path. Do not press MLB switch, 7.5dB remains disabled. Unit scrolls to the next option.

NET LBO 15dB LED flashes when local provisioning begins. Press MLB switch once to enable 15dB loss in receive path. Do not press MLB switch, 15dB remains disabled and unit returns to normal operation.

Note

If MLB switch is not pressed for either the 7.5 or 15dB NET LBO option, unit automatically sets NET LBO option to 0dB then returns to normal operation.

Performance Monitoring and Reporting

7.03 Performance Report Messages (PRMs) are generated and sent by various T1 path termination devices such as Channel Service Units (CSUs) or Line Interface Units (LIUs) to provide a view of the received T1 signal. PRMs are inserted in the ESF Data Link to communicate information, non-intrusively, to Data Collecting Equipment or Network Test Heads. The 520-50 supports the proposed methodology for Network Performance Report Messages (NPRMs) stated in the 1998 ANSI T1.403 DS1 Metallic Interface standards.

7.04 The 520-50 continuously monitors the DS1 bit stream in both the Network-to-Customer and Customer-to-Network direction and records certain performance statistics which can be retrieved for verification that service performance parameters are being achieved or to locate error conditions. Examples of the various performance screens are shown in Figures 4 through 11.

Craft Interface Port (RS-232)

7.05 The 520-50 provides a front-panel RS-232 Craft Interface Port that allows local access to the performance functions of the unit. See Section 10, Set Up and Operation, for details. **Note:** A VT-100 terminal is not required to set the transmission options such as LBO, regeneration, Customer LOS or Loopback Timeout. These settings are described in detail in Section 4 (Provisioning) and/or Section 7 (Front-Panel Features).

8. Installation



**CAUTION
STATIC SENSITIVE**



This equipment contains static sensitive components. Be sure proper electrostatic discharge procedures are followed before handling/installing the equipment.

8.01 The following warning information is required by the ETL Safety Testing Laboratory:

Safety Notes

- (1) Never install telephone wiring during a lightning storm.
- (2) Never install telephone jacks in wet locations unless the jack is designed for wet locations.
- (3) Never touch un-insulated telephone wires or terminals unless the telephone line has been disconnected at the network interface.
- (4) Use caution when installing or modifying telephone lines.
- (5) When installed, this unit is to be used behind devices that provide primary lightning protection.

Installer Connections

8.02 The 520-50 is a slim-type unit (i.e., 200-mechanics) compatible with any single or multiple universal Network Channel Termination Equipment (NCTE) mounting designed to house slim-type or 400-type cards. Connections required by the 520-50 are listed in Table 1. See appropriate mounting practice for installation information.

Table 1. Installer Connections

LEAD DESIGNATION		PIN#
T	NET IN (Tip)	7
R	NET IN (Ring)	13
T1	NET OUT (Tip 1)	41
R1	NET OUT (Ring 1)	47
T1	CPE OUT (Tip 1)	5
R1	CPE OUT (Ring1)	15
T	CPE IN (Tip)	55
R	CPE IN (Ring)	49
PWR	Power IN (-PWR)	35
GND	Ground (+PWR)	17
CH GND	Chassis Ground	27
ALM	Alarm Out	25

8.03 The 520-50 is equipped with a 2-position slide switch (S2) labeled LOCAL and SPAN and a 2-position DIP switch (S3), labeled CPE LOS. Set these switches to the appropriate settings before installing the unit.

9. Testing

9.01 Testing consists of performing the procedures outlined in Table 2 to verify that the loopback function is operating properly. These procedures are intended only to ascertain proper operation of the unit. Tests beyond those outlined, or repairs made beyond replacing a faulty unit, are not recommended and may void the warranty.

9.02 If trouble is encountered, verify all options are set and that all wiring connections are properly made. If trouble persists, replace the unit and repeat the procedures outlined. If technical assistance is required, contact the HyperEdge Customer Care Department.

10. Setup and Operation

Craft Terminal Setup and Operation

10.01 The front-panel craft interface port allows the craft to view stored T1 performance statistics and circuit status.

10.02 The craft interface port is a DB-9 connector with an electrical RS-232 female interface in a DCE configuration. The craft device used can be a terminal operating in the VT-100 protocol or a PC running a VT-100 terminal emulation program. If a VT-100 terminal is used, a “null-modem” cable may be required between the terminal and the NIU. If a PC with VT-100 emulation program is used, a standard RS-232 cable can be used. The terminal RS-232 port should be set up for 9600 baud, 8 data bits, no parity, and one stop bit. The electrical connections to the craft port are shown in Figure 3.

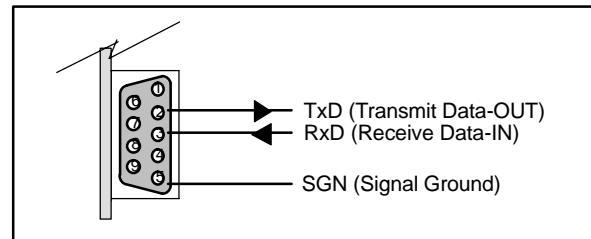

Figure 3. Front-Panel RS-232 (DB9)

MAIN Menu Screen

10.03 Once the terminal or PC is connected to the craft port, the MAIN menu should appear. The MAIN menu provides the NIU model number as well as navigation buttons to other screens. The MAIN menu is shown in Figure 4. To return to the MAIN menu screen from any other screen enter <Esc>.

Other Performance Screens

10.04 From the Main Menu, the test person can access the various other Performance screens which are shown in Figures 5 through 11.

Table 2. 520-50 Test Procedures

Step	Action	Results
1.	Option and install unit	
2.	Apply Power If Span Powered, verify current at Span Current test points	Verify PWR LED is ON Voltage should read 0.6 Volts ($\pm 0.03V$) for 60mA operation
3.	Press front-panel MLB switch	Verify LPBK LED lights; Unit enters Loopback
4.	Send Quasi-Random signal to unit	Verify QRSS Test code on RCV pair from unit
5.	Press front-panel MLB switch again	Verify LPBK LED is OFF; Unit returns to normal
6.	Send loop-up code to unit Inband – 11000 (>5 seconds) ESF – 0001 0010 1111 1111 (>16ms)	Verify LPBK LED lights and that loop-up code is present on RCV pair from unit; Unit enters Loopback
7.	Perform Bit Error Rate (BER) test	BER must be within acceptable limits
8.	Send loop-down code to unit Inband – 11100 (> 5 seconds) ESF – 0010 0100 1111 1111 (>16ms)	Verify LPBK LED is OFF; Unit returns to normal

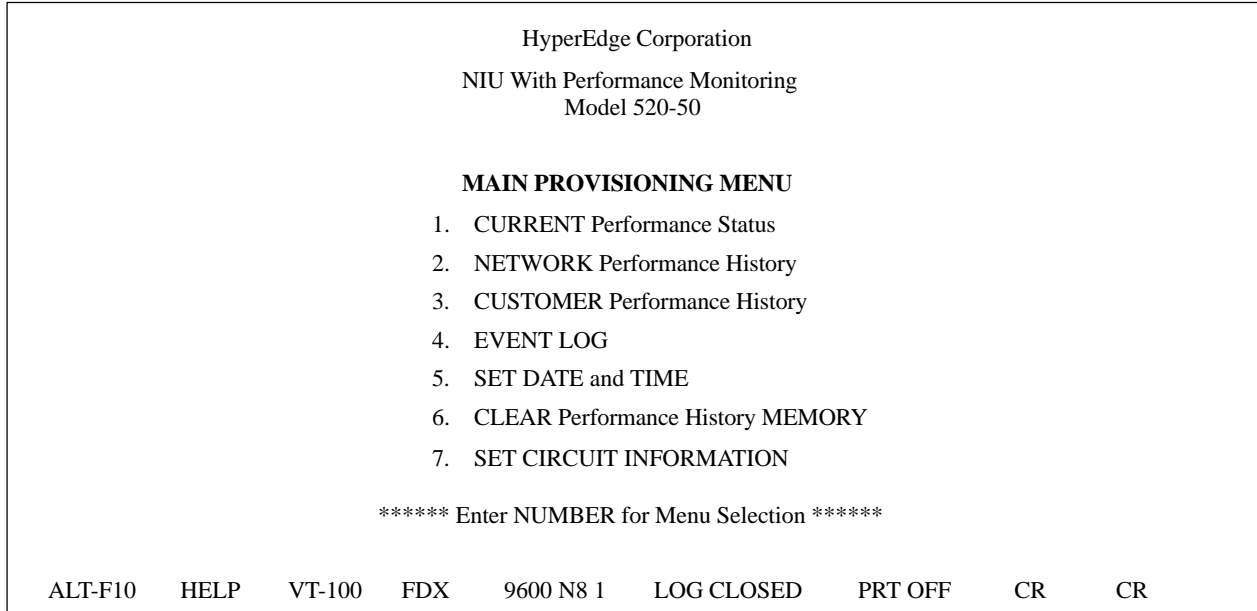

Figure 4. Main Menu Screen

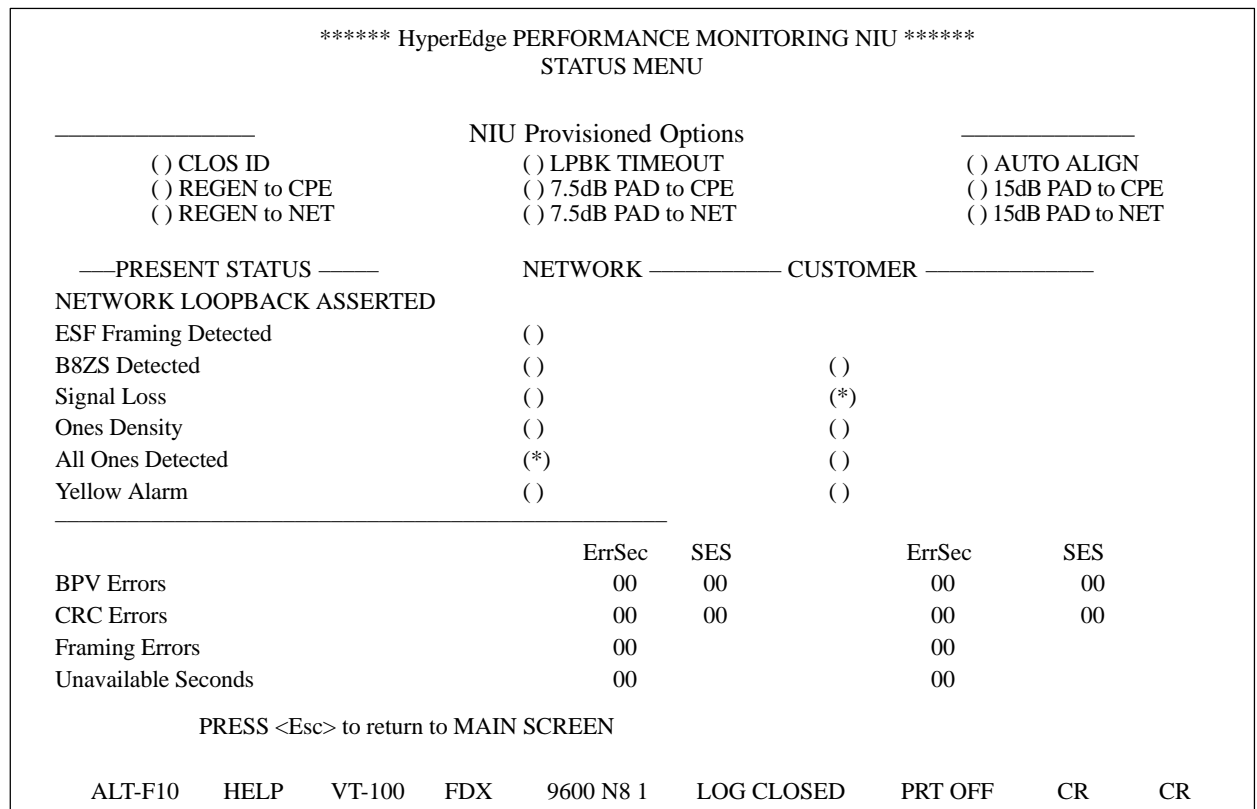

Figure 5. Typical Current Performance Status Screen

HyperEdge Corporation									
PERFORMANCE MONITORING NIU									
Network History Menu									
<-CURRENT 15 MINUTE->					<- 1 HOUR HISTORY->				
	ErrSec	SES			ErrSec	SES			
BPV Errors	000	000			000	000			
CRC Errors	000	000			000	000			
Framing Errors	000				000				
Unavailable Seconds	000				000				
<-24 HOUR HISTORY->					<- 7 DAY HISTORY->				
	ErrSec	SES			ErrSec	SES			
BPV Errors	00000	00000			00000	00000			
CRC Errors	00000	00000			00000	00000			
Framing Errors	00000				00000				
Unavailable Seconds	00000				00000				
PRESS <Esc> to return to MAIN SCREEN									
ALT-F10	HELP	VT-100	FDX	9600 N8 1	LOG CLOSED	PRT OFF	CR	CR	

Figure 6. Typical Network History Screen

HyperEdge Corporation									
PERFORMANCE MONITORING NIU									
Customer History Menu									
<-CURRENT 15 MINUTE->					<- 1 HOUR HISTORY->				
	ErrSec	SES			ErrSec	SES			
BPV Errors	000	000			000	000			
CRC Errors	000	000			000	000			
Framing Errors	000				000				
Unavailable Seconds	000				000				
<-24 HOUR HISTORY->					<- 7 DAY HISTORY->				
	ErrSec	SES			ErrSec	SES			
BPV Errors	00000	00000			00000	00000			
CRC Errors	00000	00000			00000	00000			
Framing Errors	00000				00000				
Unavailable Seconds	00000				00000				
PRESS <Esc> to return to MAIN SCREEN									
ALT-F10	HELP	VT-100	FDX	9600 N8 1	LOG CLOSED	PRT OFF	CR	CR	

Figure 7. Typical Customer History Screen

HyperEdge Corporation									
PERFORMANCE EVENT LOGGING									
RESET PM REGISTERS AND EVENT LOG					10:10 AM				
PRESS <Esc> to return to MAIN SCREEN									
ALT-F10	HELP	VT-100	FDX	9600 N8 1	LOG CLOSED	PRT OFF	CR	CR	

Figure 8. Typical Event Log Screen

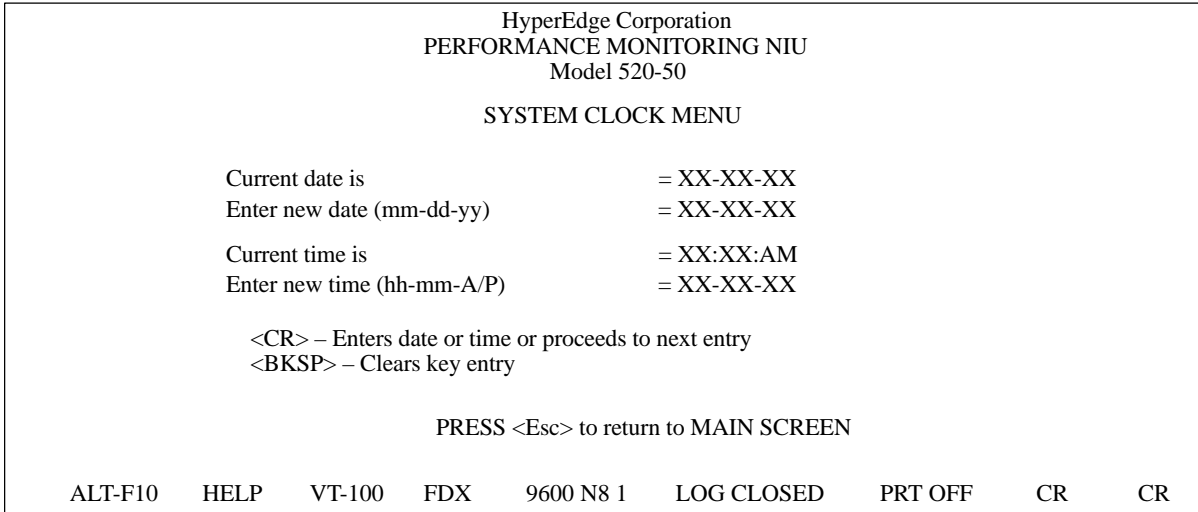

Figure 9. Set Date and Time Screen

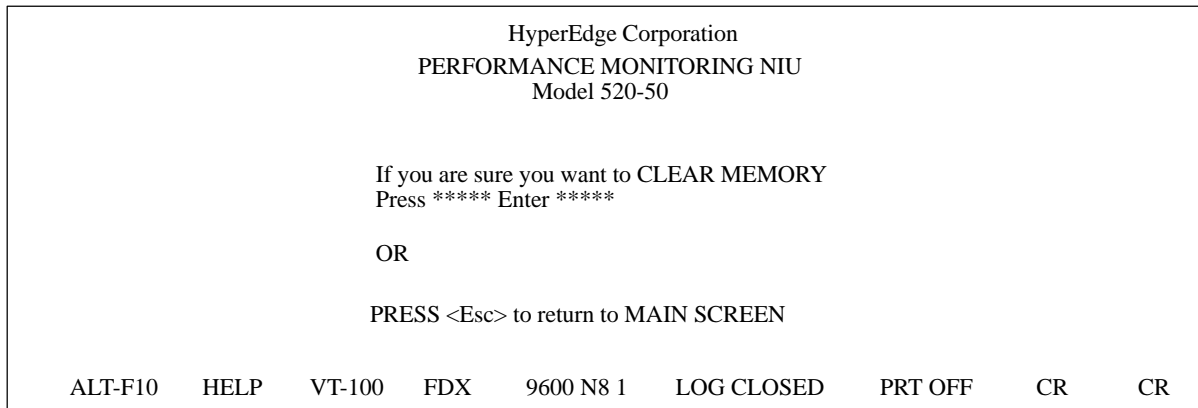

Figure 10. Clear Memory Screen

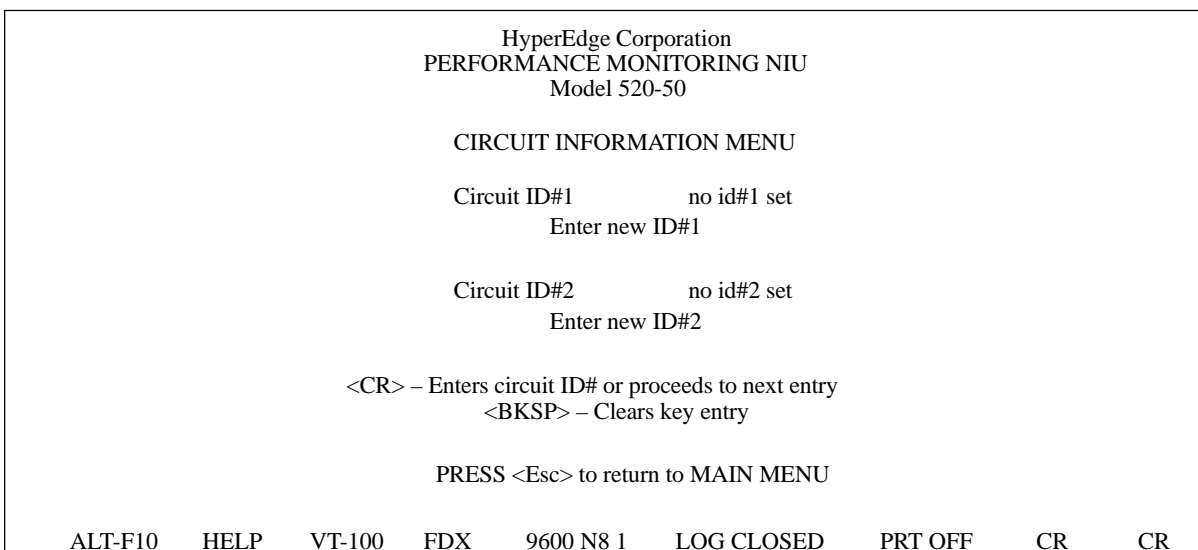

Figure 11. Set Circuit Information Screen

11. Inspection and Warranty

Inspection

11.01 Inspect the equipment upon receipt. If the equipment is damaged, please report this damage to the transportation company and to HyperEdge.

Warranty

11.02 HyperEdge warrants this product for the period specified by the terms governing the sale of the product.

11.03 Do not field repair equipment. Any attempt to repair or modify this equipment by anyone other than a representative of HyperEdge will void the warranty. If the equipment is faulty, replace it with an identical unit and retest.

Repair and Return

11.04 If the equipment is defective, please contact the HyperEdge Repair Department by calling 800-377-8766 to obtain an RMA (Return Material Authorization) number. Before returning equipment, please provide description of the problem then return the equipment to:

HyperEdge Corporation
940 Kingsland Drive
Batavia, IL 60510
ATTN: Repair Department

11.05 If equipment is defective for any reason, other than abuse or improper use, a replacement unit will be shipped.

Technical Assistance

11.06 If technical assistance is required, contact our Customer Care Department by calling:

HyperEdge Corporation
(630) 389-3600
1-800-377-8766
FAX: (630) 761-1890 or
WEB: www.HyperEdge.com

12. Specifications

Line Rate: 1.544Mb/s

Insertion Loss: 1.0dB max at 772kHz

Line Impedance: 100 ohms ($\pm 20\%$) at 772kHz

Loop-up Code:

Inband (unframed or SF): 11000 (>5 sec.)

ESF: 0001 0010 1111 1111 (>16ms)

Loop-Down Code:

Inband (unframed or SF): 11100 (>5 sec.)

ESF: 0010 0100 1111 1111 (>16ms)

Maximum Detect Error Rate: $<10^{-3}$

Loopback Timeout: 2-hour automatic timeout

Manual Loopback Activation: Press MLB switch (<1 sec., then release for NTKW Loopback; >3 sec., then release for dual loopback). Front-panel LPBK LED lights steady

Manual Loopback Deactivation: Press MLB (S1) second time or by sending loop-down code

Loopback Regeneration: 0 to 30dB line loss at 772kHz

RCV and XMT LBO: 0dB, 7.5dB or 15dB

CPE LOS: Set via S3 for Terminate, LPBK, CDI, or AIS

Power: Span Power at 57 to 63mA or local power at -48Vdc

DC Voltage Drop (Span Powered): Less than 28Vdc at 60mA

Operating Environment: Temperature -40 to 149°F (-40 to 65°C); Humidity, 0 to 95%, no condensation

Dimensions: Height, 5.6"; Width 0.7"; Depth 5.9"

Weight: Approximately 12 oz.

13. Ordering Information

520-50 – DS1 Network Interface Unit w/PM