

NGN EQUIPMENT RACK

Modified:10/01/2009

CLOSED BAY
(GUARD BOX ON WIDE FLANGE)

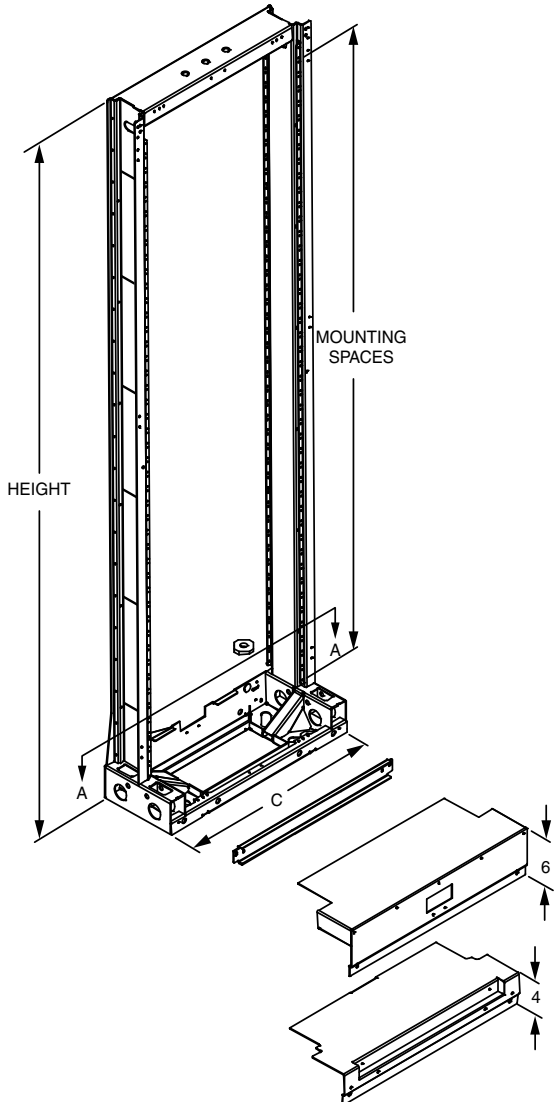

OPEN BAY
(GUARD BOX ON NARROW FLANGE)

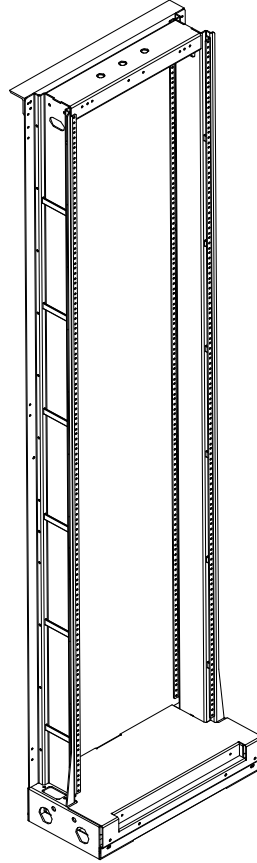

	width	A	B	C	D	E	F
	23"	21-3/4"	22-5/16"	25-7/8"	23-7/8"	17-7/16"	12-3/8"
	19"	17-3/4"	18-5/16"	21-7/8"	19-7/8"	13-7/16"	8-3/8"

SECTION A-A

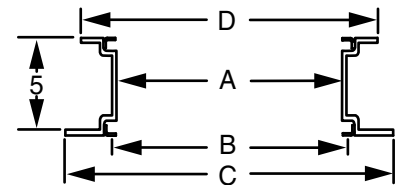

UPRIGHT PROFILE
(NOTE 1)

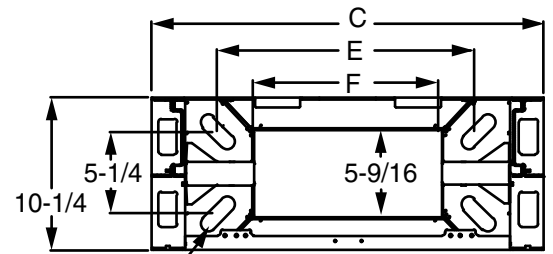

1" x 2-3/4" SLOT
(TYP 4 PLC)

	description	mounting spaces
UFER	WECCO 1"; 12-24	74
	EIA Universal (5/8" x 5/8" x 1/2"); 12-24	42
	EIA Wide (1-1/4" x 1/2"); 12-24	42

	description	mounting spaces
Netbay	WECCO 1"; 12-24	76
	EIA Universal (5/8" x 5/8" x 1/2"); 12-24	44
	EIA Wide (1-1/4" x 1/2"); 12-24	44

Features

- Designed specifically to cross the boundary of EIA and GR-63.
- This is a seismically tested (Zone 4) rack with 17.75" between the uprights on the 19" version (according to the EIA 310 guidelines). It provides open access to the base and integral cable tie bars for faster installation.

Ordering information

Use the following to determine the ten-character ordering number of the ngn type rack desired. The ordering number is constructed as follows

Examples:

Ordering number 0049300131 specifies an ngn seismic unequal flange equipment rack (ufer), 19" equipment mounting, closed duct, 1" mounting hole pattern, 7'-0" height, without a top angle, finish code 31 (gray).

Ordering number 0049770264 specifies an ngn seismic network bay (snw bay), open duct, 23" equipment mounting, eia universal hole pattern (5/8" - 5/8" - 1/2"), 7' - 0" height, with a top angle, finish code 64 (blue).

0049xxxxxx

0049	A	B	CC	XX
0049: NEXT GENERATION NETWORK (NGN)				XX: FINISH CODE 31 = GRAY 64 = BLUE
A: RACK TYPE & EQUIPMENT MOUNTING WIDTH 2 = SEISMIC UNEQUAL FLANGE EQUIPMENT RACK (SUFER); 23" 3 = SEISMIC UNEQUAL FLANGE EQUIPMENT RACK (SUFER); 19" 7 = SEISMIC NETWORK BAY (SNW BAY); 23" 8 = SEISMIC NETWORK BAY (SNW BAY); 19"			CC: RACK HEIGHT & TOP ANGLE 01 = 7' - 0" HEIGHT; 02 = 7' - 0" HEIGHT; WITH TOP ANGLE 04 = 7' - 6" HEIGHT; WITH TOP ANGLE 06 = 8' - 0" HEIGHT; WITH TOP ANGLE	
B: DUCT TYPE, EQUIPMENT MOUNTING HOLE PATTERN 0 = CLOSED DUCT, 1" HOLE PATTERN; 12-24 1 = CLOSED DUCT, EIA WIDE (1-1/4" - 1/2") HOLE PATTERN; 12-24 2 = CLOSED DUCT, EIA UNIVERSAL (5/8" - 5/8" - 1/2") HOLE PATTERN; 12-24 5 = OPEN DUCT, 1" HOLE PATTERN; 12-24 6 = OPEN DUCT, EIA WIDE (1-1/4" - 1/2") HOLE PATTERN; 12-24 7 = OPEN DUCT, EIA UNIVERSAL (5/8" - 5/8" - 1/2") HOLE PATTERN; 12-24				

Notes

- Dimensional information: refer to table a.
- Equipment mounting: refer to tables for mounting hole spacing and mounting spaces. All racks are double side drilled and tapped as shown.
- Meets the earthquake criteria (seismic Zone 4) of Telcordia document . GR-63-core, issue 1, sections 4.4 And 5.4, When loaded with 500 pounds to simulate rack mounted equipment.
- Base mounting pattern (refer to section a-a) meets the criteria of gr-63-core, figure 2-1b.
- Product weight (pounds, approximate): 7'-0" (100).