

RANGE SUMMARY

The EnerSys® range of PowerSafe™ V Front Terminal batteries has been designed specifically for use in applications that demand the highest levels of security and reliability. With proven compliance to the most rigorous international standards, PowerSafe V batteries are recognized worldwide as a premium battery for Telecom applications. The PowerSafe V battery's reputation for long service life, together with excellent high rate performance, also makes it ideal for high integrity, high specification UPS systems.

PowerSafe V batteries deliver superior performance while occupying less space than conventional standby power batteries. The PowerSafe V Front Terminal battery's compact design, suitable for 19", 23" and ETSI racking, provides users with the benefit of increased energy density. With all electrical connections at the front, installation and inspection are both quicker and easier.

PowerSafe V batteries are designed using proven gas recombination technology, which removes the need for regular water addition by controlling the evolution of hydrogen and oxygen during charging. Oxygen evolved at the positive plates diffuses through microporous separators to the negative plates, and, by a series of chemical reactions within the cell, recombines to form water. Each cell incorporates its own safety valve that allows the controlled release of gas when pressure builds up within the cell.

The use of gas recombination technology for lead acid batteries has totally changed the concept of standby power. This technology provides the user with the freedom to use lead acid batteries in a wide range of applications.

Features & Benefits

- Capacity range: 31Ah - 170Ah
- Front terminal connections for fast and easy installation and maintenance
- Suitable for 19", 23" and ETSI racking
- UL94 V-0 flame retardant container and cover
- High reliability
- Proven long service life



EnerSys®

Power/Full Solutions

RESERVE
POWER

Construction

- Positive plates designed to prolong service life and enhance corrosion resistance
- Separators in low resistance microporous glass fiber. The electrolyte is absorbed within this material, preventing acid spills in case of accidental damage
- Container and cover in flame retardant ABS material, highly resistant to shock and vibration
- Terminal with brass insert for maximum conductivity and with high compression grommet for long life
- Self-regulating pressure relief valve prevents ingress of atmospheric oxygen

Installation & Operation

- The PowerSafe™ V Front Terminal battery range is designed for installation in cabinets or on stands, close to the point of use. A separate battery room is not necessary
- It is recommended that PowerSafe V Front Terminal batteries are installed on their base
- Recommended float charge voltage 2.280Vpc at 68°F (20°C) 2.265Vpc at 77°F (25°C)
- Six-month shelf life
- Reduced maintenance - no water addition required

Standards

- In compliance with the requirements of the international IEC 60896-21/22 standard
- Designed to meet Telcordia SR-4228 requirements
- Recognized by UL (UL Standard 1989)
- Approved to be shipped as non-hazardous cargo in accordance with the requirements of IMDG (International Maritime code for Dangerous Goods) and ICAO (International Civil Aviation Organization)
- Manufactured in EnerSys® ISO 9001:2000 certified production facilities

General Specifications

Type	Number of Cells	Nominal Voltage (V)	Nominal Capacity (Ah)		Nominal Dimensions				Overall Height		Typical Weight		Short Circuit Current (A)	Internal Resistance (mΩ)	Terminals
			10 hr rate to 1.80Vpc @ 20°C	8 hr rate to 1.75Vpc @ 77°F	Length mm	in	Width mm	in	mm	in	kg	lbs			
12V30F	6	12	31	31	303	11.9	97	3.8	159	6.3	10.8	23.8	1327	9.87	M6 M
12V38F	6	12	38	38	303	11.9	97	3.8	184	7.2	12.5	27.6	1500	8.53	M6 M
12V62F	6	12	62	62	303	11.9	97	3.8	264	10.4	19.7	43.5	2100	5.87	M6 M
12V92F-FT*	6	12	92	92	417	16.4	105	4.1	256	10.1	28.0	61.7	2500	5.05	M6 M
8V100F*	4	8	100	100	384	15.1	125	4.9	228	9.0	32.0	70.5	3636	2.20	M6 M
12V100F*	6	12	100	100	558	22.0	125	4.9	228	9.0	47.5	104.7	3636	3.30	M6 M
12V105F*	6	12	105	107	561	22.1	125	4.9	235	9.3	46.0	101.4	2763	4.40	M6 M
12V125F*	6	12	125	126	561	22.1	105	4.1	316	12.4	51.0	112.4	2845	4.30	M6 M
12V145F*	6	12	145	145	452	17.8	172	6.8	238	9.4	47.6	105.0	4100	3.00	M6 M
12V155FS*	6	12	150	155	561	22.1	125	4.9	283	11.1	57.0	125.6	3714	3.30	M6 M
12V170F*	6	12	170	170	561	22.1	125	4.9	316	12.4	67.0	147.7	3667	3.40	M6 M

* With rope handles

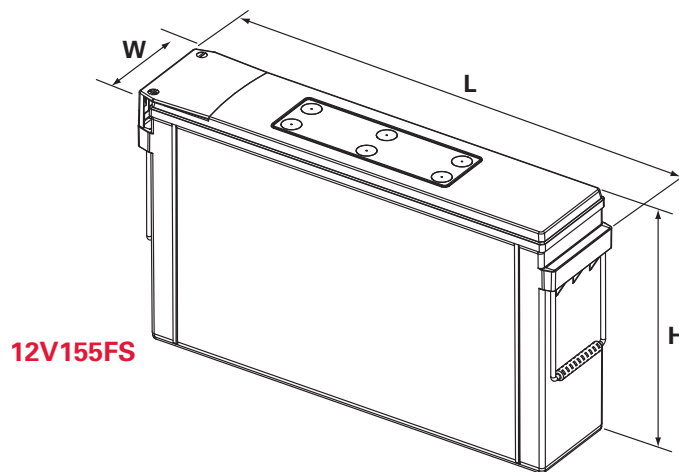

www.enersys.com

EnerSys
P.O. Box 14145
Reading, PA 19612-4145
USA
Tel: +1-610-208-1991
+1-800-538-3627
Fax: +1-610-372-8613

EnerSys Europe
Zurich, Switzerland

EnerSys Asia
Guangdong, China
Tel: +86-755-2689 3639

Distributed by:

© 2008 EnerSys. All rights reserved.
Trademarks and logos are the property of EnerSys and its affiliates unless otherwise noted.