



RELEASE 1.1

# TimeProvider 5000

IEEE 1588-2008 Stratum 1 Grandmaster Clock

## KEY FEATURES

- Carrier-Class Architecture
- Redundant Power and Clock Modules
- Automatic Failover
- Hardware-Based Time Stamping
- Multiple VLAN Support
- PTP Telecom Profile
- Rubidium and/or Quartz Oscillators
- Interoperable with 3rd-Party PTP Clients
- Node Manager Function (PTP Clause 15)
- PTP Client Metrics
- TimePictra and TimeScan Support
- SNMP and CLI Management
- Software Configurable Outputs
- Optical and Electrical SFP Interfaces
- GigE Optical and Electrical Interfaces

## KEY BENEFITS

- Precise Timing and Synchronization over IP/Packet-Based Networks
- Eliminates the need for GPS at RNC/BSC locations
- Rapid Migration to Ethernet Backhaul
- Maximizes Network Uptime and QoS
- Minimizes Service Interruptions and Potential Outages
- Outstanding Scalability
- Complete End-to-End PTP Solution

## PRODUCT OVERVIEW

TimeProvider 5000 is a carrier-class IEEE 1588-2008 Grandmaster clock that utilizes a fully-redundant architecture to guarantee maximum uptime and resiliency.

TimeProvider 5000 combines the functionality of a highly accurate, IEEE 1588-2008 Grandmaster Clock with 2.048MHz/E1 and 10MHz/1pps I/O ports in a high-performance, yet highly compact 1RU footprint.

Ideally suited for deployment at remote Radio Network Controller (RNC) and Base Station Controller (BSC) sites where rack space and real estate are extremely limited, TimeProvider 5000 adheres to the latest IEEE 1588-2008 standard, including the provisioning of IEEE 1588 telecom profile extensions for telecommunications-based applications.

TimeProvider 5000 incorporates hardware-based time stamping which provides precise timing and frequency over a broad range of wireline and wireless applications. TimeProvider 5000 is available with both Quartz and Rubidium oscillator options, enabling service providers and network equipment manufacturers to choose the optimal level of holdover based on network performance, application requirements and equipment cost targets.

When combined with Symmetricom's TimeProvider 500 PTP Translators and TimePictra Element Management System, TimeProvider 5000 delivers end-to-end PTP management with complete visibility into the operation and performance of all PTP clients located within the network.

Because it is IEEE 1588-2008 standards compliant, TimeProvider 5000 is fully interoperable with standalone and embedded PTP clients from third party vendors and also provides management of third party PTP clients via its IEEE 1588 Node Manager (clause 15) function.

## APPLICATIONS

TimeProvider 5000 is "purpose built" to handle the most stringent frequency and timing requirements of today's next generation networks, enabling service providers to roll out new packet-based services without having to sacrifice quality of service.

Typical applications include:

- Wireless Ethernet Backhaul (UMTS)
- Circuit Emulation Services (CES)
- Passive Optical Networks (PON)
- WiMAX
- LTE



TimeProvider 5000 IEEE 1588-2008 Grandmaster Clock

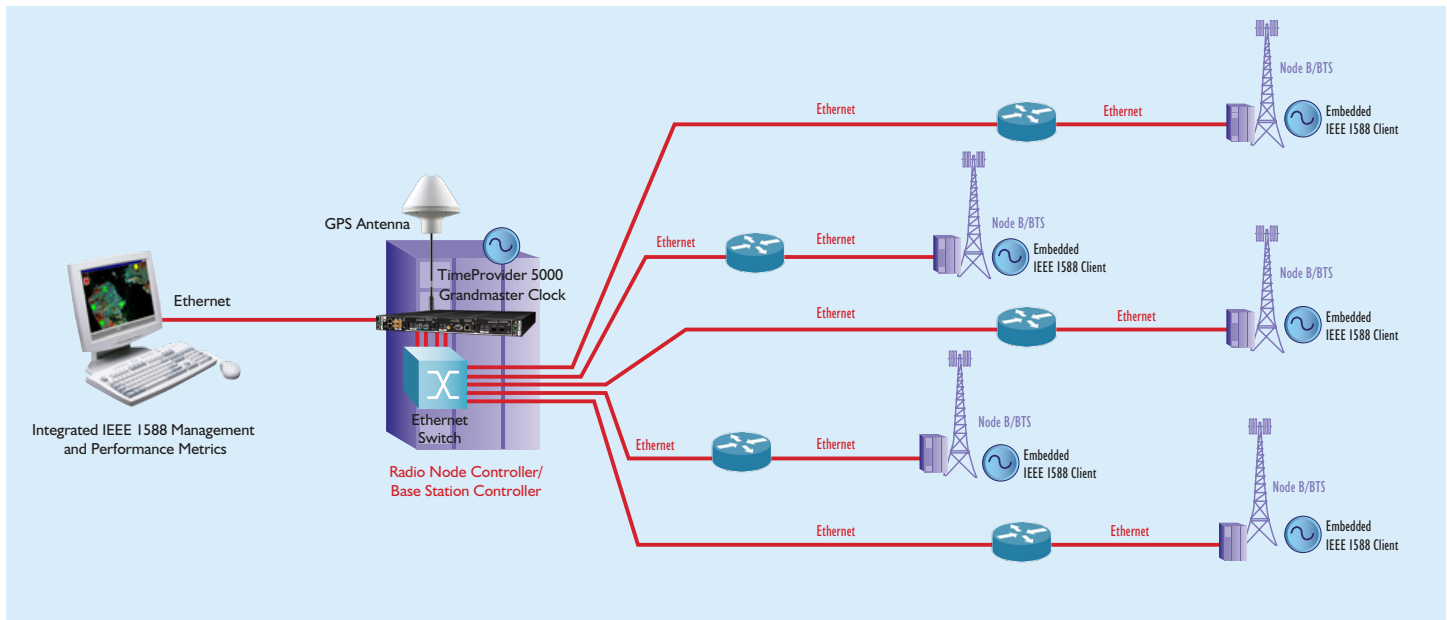

Typical wireless backhaul application utilizing the TimeProvider 5000 Grandmaster Clock with fully redundant, carrier-class architecture to provide precise timing and frequency for remote base stations over a packet-based Ethernet network infrastructure.

## TimeProvider 5000 Specifications

### INPUTS

- 1 X GPS
- 2x E1 (2.048 Mbps and 2.048 MHz)
- 2X DTI/UTI

### OUTPUTS

- 1 X 10MHz (Optional)
- 1 X 1 PPS (Optional)
- 2x GigE output per IOC (optical and electrical)
- 4x GigE output per system (optical and electrical)
- 2X DTI/UTI

### PHYSICAL SPECIFICATIONS

- Dimensions: 44mm H x 483mm W x 435mm D (1.75" H x 19" W x 17" D)
- Weight: 4.4 kg (9.6 lbs)

### POWER REQUIREMENTS

- -40 VDC to -60 VDC (dual redundant) @ 36 W, typical consumption

### ENVIRONMENTAL SPECIFICATIONS

- Operating temperature: -5°C to +45°C

### HARDWARE MODULES

- I/O Module (includes 4 x I/O ports)
- IMC Module
- IOC (Quartz) Module
- IOC (Rubidium) Module

### ANTENNA TYPE

- L1 Band

### HOLDOVER

- Rubidium (Type II) <1x10<sup>-11</sup>/day or 10 μ sec over 5 days (over constant temperature)
- Quartz (Type I) <1x10<sup>-10</sup>/day or 10 μ sec over 1 day (over constant temperature)

### TIME OF DAY ACCURACY

- <100 nsecs when locked to GPS

### INDUSTRY STANDARDS/REQUIREMENTS

- ITU G.811, G.812, G.823, G.8261
- G.703, G.704, ETSI 300/Class 3.1

### PROTOCOLS

- IEEE 1588-2008 (PTP)
- IPv4
- DHCP
- SFTP, FTP
- DiffServ/DSCP
- VLAN (up to 16)
- TELNET
- SYSLOG
- RADIUS

### MANAGEMENT

- TimePictra
- TimeScan
- SNMP v2c, v3 (north and southbound)
- TELNET, SSH
- CLI

### CERTIFICATIONS

- CE

### EMC

- EN300 386, EN55022/24, CIS PR22, KN55022/24, FCC Part 15, AS/NZS Class B
- VCCI Class A

### SAFETY

- UL/cUL 60950-1, IEC 60950-1/CB, EN60950-1, ULde/GS

### ENVIRONMENTAL

- ETSI EN 300 019, Class T3.2

### RoHS

- 2002/95/EC as amended by 2005/717/EC, 2005/747/EC, and 2005/618/EC